

# BX-1000 BLACK MAX



**Black  
Max**

**PLEASE READ THROUGH THE ENTIRE MANUAL BEFORE INSTALLING YOUR BRAKE SYSTEM**

**WARNING - DO NOT USE BRAKE FLUID - USE ATF HYDRAULIC FLUID ONLY**

- \*\*IMPORTANT\*\*** DO NOT USE ANY OTHER SEALS OTHER THEN WHAT IS SUPPLIED WITH THIS SYSTEM. INCOMPATIBLE SEALS WILL RESULT IN SYSTEM FAILURE
- \*\*IMPORTANT\*\*** USE ATF FLUID ONLY (*Automatic Transmission Fluid*) ANY OTHER FLUID MAY DAMAGE THE SYSTEM
- \*\*IMPORTANT\*\*** DO NOT USE BRAKE FLUID WITH THIS SYSTEM. BRAKE FLUID WILL DAMAGE THE SEALS
- \*\*IMPORTANT\*\*** DO NOT EXCEED THE GROSS WEIGHT LIMIT OF 1000 LBS
- \*\*IMPORTANT\*\*** USE PROVIDED LOCK NUTS AND LOCK WASHERS TO PREVENT WHEEL FROM LOOSENING
- \*\*IMPORTANT\*\*** REPLACE TIRES ANNUALLY OR WHEN SHOWING EXCESSIVE WEAR.
- \*\*IMPORTANT\*\*** DO NOT USE IF THERE IS ANY SIGN OF LEAKING. MAKE REPAIRS IMMEDIATELY
- \*\*IMPORTANT\*\*** MOUNT CALIPER WITH A BLEEDER SCREW LOCATED IN THE TOP POSITION ONLY. USE THE NYLON TIPPED SET SCREWS TO PLUG THE TWO OTHER UNUSED BLEEDER SCREW LOCATIONS.
- \*\*IMPORTANT\*\*** MOUNT THE MASTER CYLINDER IN AN UPRIGHT POSITION TO PREVENT OIL FROM LEAKING FROM THE VENT PLUG.  
***NOTE: MASTER CYLINDER CAN BE MOUNTED SIDEWAYS WITH SPECIAL VENT KIT.***
- \*\*IMPORTANT\*\*** NOTICE THE ATF HYDRAULIC FLUID WILL DISCOLOR IN DIRECT SUN LIGHT AND SHOW CLEAR IN SOME AREAS AND WILL APPEAR AS IF THERE IS AIR IN THE LINES
- \*\*IMPORTANT\*\*** ALWAYS REPLACE THE NYLOCK AXLE NUT AFTER REMOVING IT MORE THEN TWO TIMES

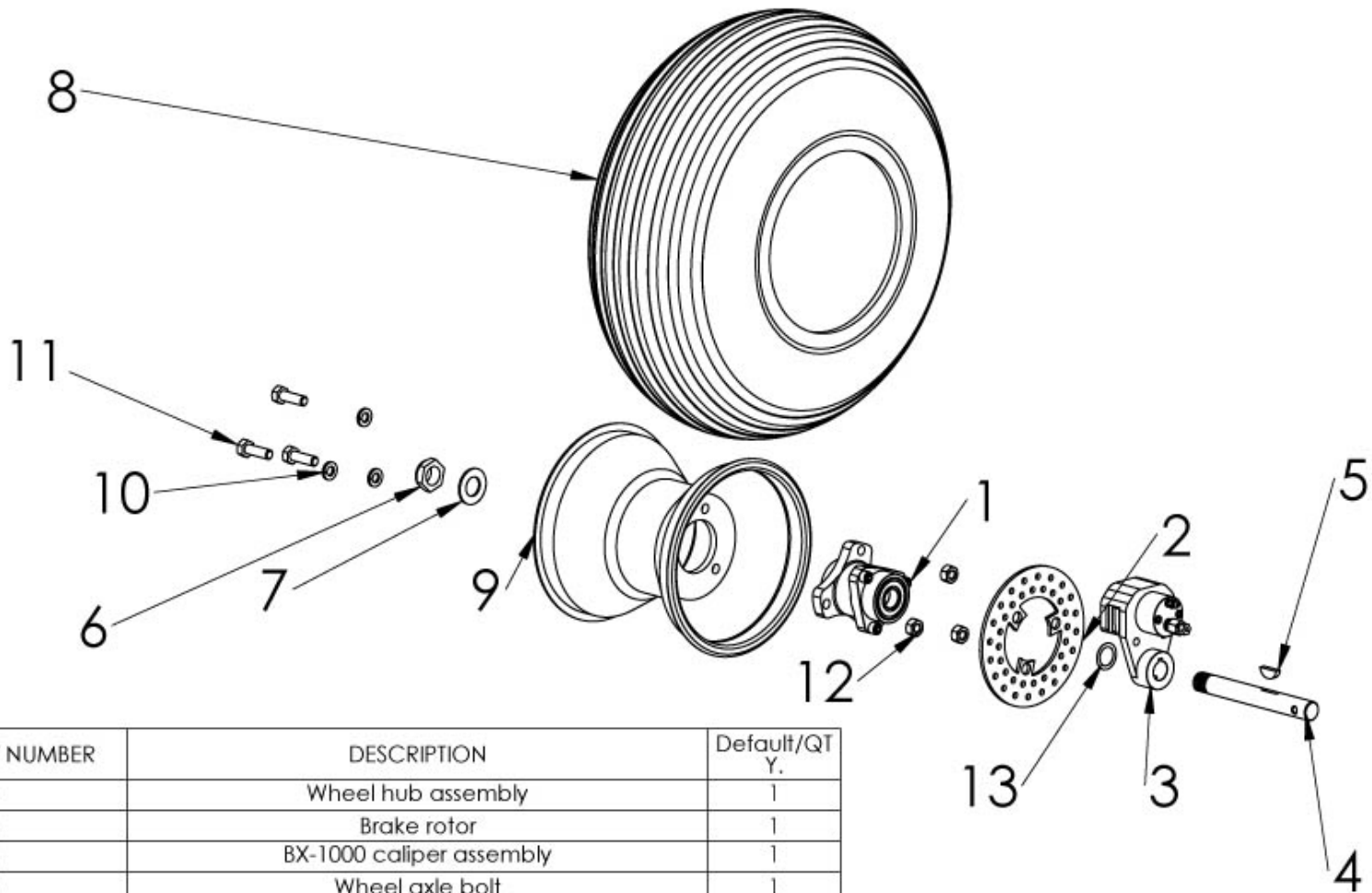

ITEM NO.	PART NUMBER	DESCRIPTION	Default/QT Y.
1	44772	Wheel hub assembly	1
2	44746	Brake rotor	1
3	44766	BX-1000 caliper assembly	1
4	44748	Wheel axle bolt	1
5	44750	woodruff key	1
6	15101	5/8"-11 Nyloc thin nut	1
7	AN960-1016	5/8" Flat washer	1
8	14303	6" tire	1
9	14302	6" polished aluminum wheel	1
10	LW 0.3125		3
11	HBOLT 0.3125- 18x1x1-N		3
12	HNUT 0.3125- 18-D-N		3
13	44845	Caliper spacer washer	1

Notes:

**UNLESS OTHERWISE SPECIFIED:**  
 DIMENSIONS ARE IN INCHES  
 TOLERANCES:  
 FRACTIONAL  $\pm 1/8"$   
 ANGULAR: MACH  $\pm .5^\circ$  BEND  $\pm 1^\circ$   
 TWO PLACE DECIMAL  $\pm .030$   
 THREE PLACE DECIMAL  $\pm .005$

MATERIAL

FINISH

DO NOT SCALE DRAWING



TITLE:

BX-1000 wheel/brake assembly

Part #

Qty Req'd

SCALE: 1:8

WEIGHT:

REV:

5

4

3

2

1

REVISIONS		
REV.	DESCRIPTION	DATE
A	Added new handle and spring pin for positive stop	3/24/2008

ITEM NO.	PART NUMBER	DESCRIPTION	Default/QTY
1	44742	Master Cylinder	1
2	44747	Brake handle	1
3	44756	1/8" NPT to 1/8" tube compression fitting	1
4	44758	1/8" NPT plug	1
5	44759	1/8" NPT vent plug	1
6	44761	Return spring	1
7	44760	1/8" NPT plug	1
8	44763	1/4"-20 SHCS S.S.	1
9	44762	Shoulder screw	1
10	44749	O-ring	2
11	44745	Master cylinder piston	1
12	44776	Cup Seal	1
13	44777	Cup seal washer	1
14	44747	Brake handle	1
15	44784	Foot brake lever	1
17	44881	spring pin	1

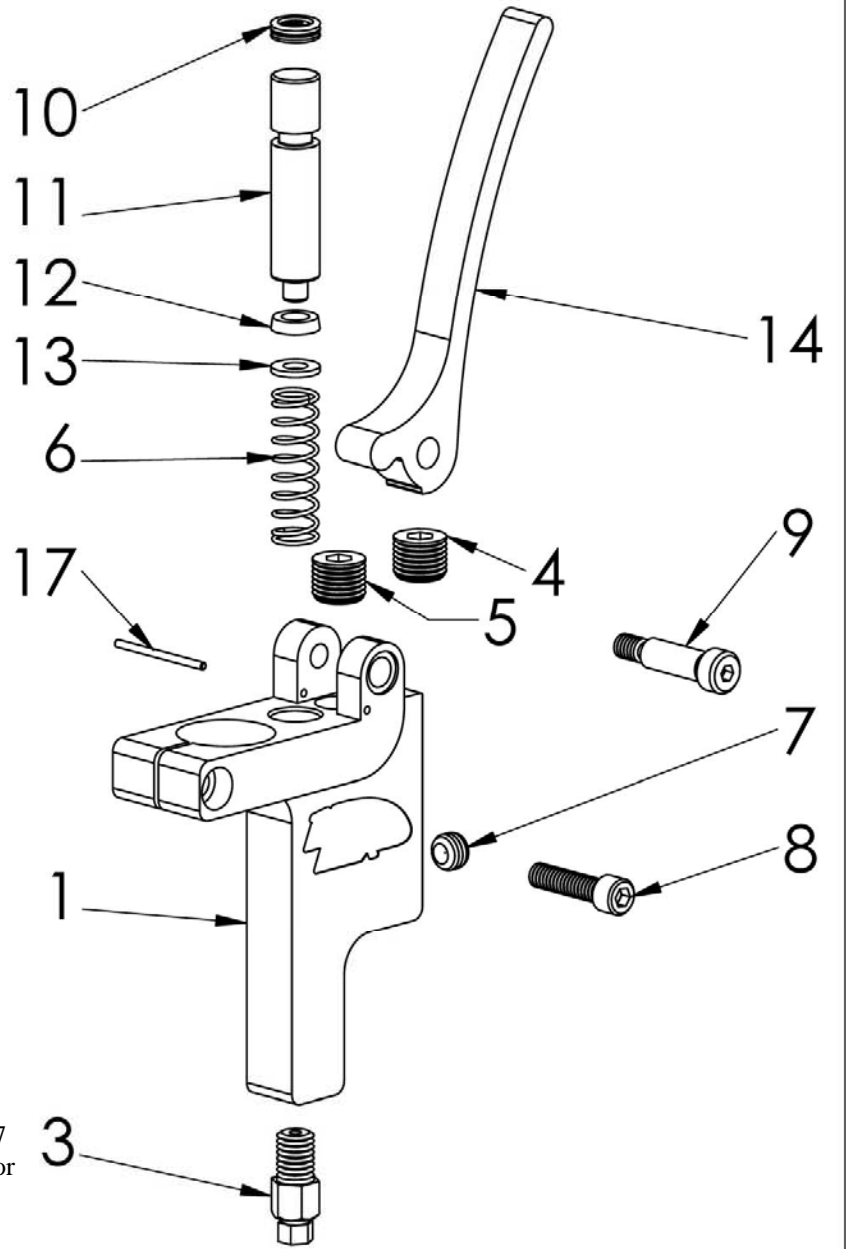

Notice: If replacing item 3, 5, or 7 make sure to use a loctite sealant or teflon tape.

Notes:

**UNLESS OTHERWISE SPECIFIED:**  
 DIMENSIONS ARE IN INCHES  
 TOLERANCES:  
 FRACTIONAL ±1/8"  
 ANGULAR: MACH ± .5° BEND ±1°  
 TWO PLACE DECIMAL ±.030  
 THREE PLACE DECIMAL ±.005

MATERIAL  
 FINISH  
 DO NOT SCALE DRAWING



TITLE: Master Cylinder Assembly		
Part #	44764	Qty Req'd A
SCALE: 1:8	WEIGHT:	REV:2

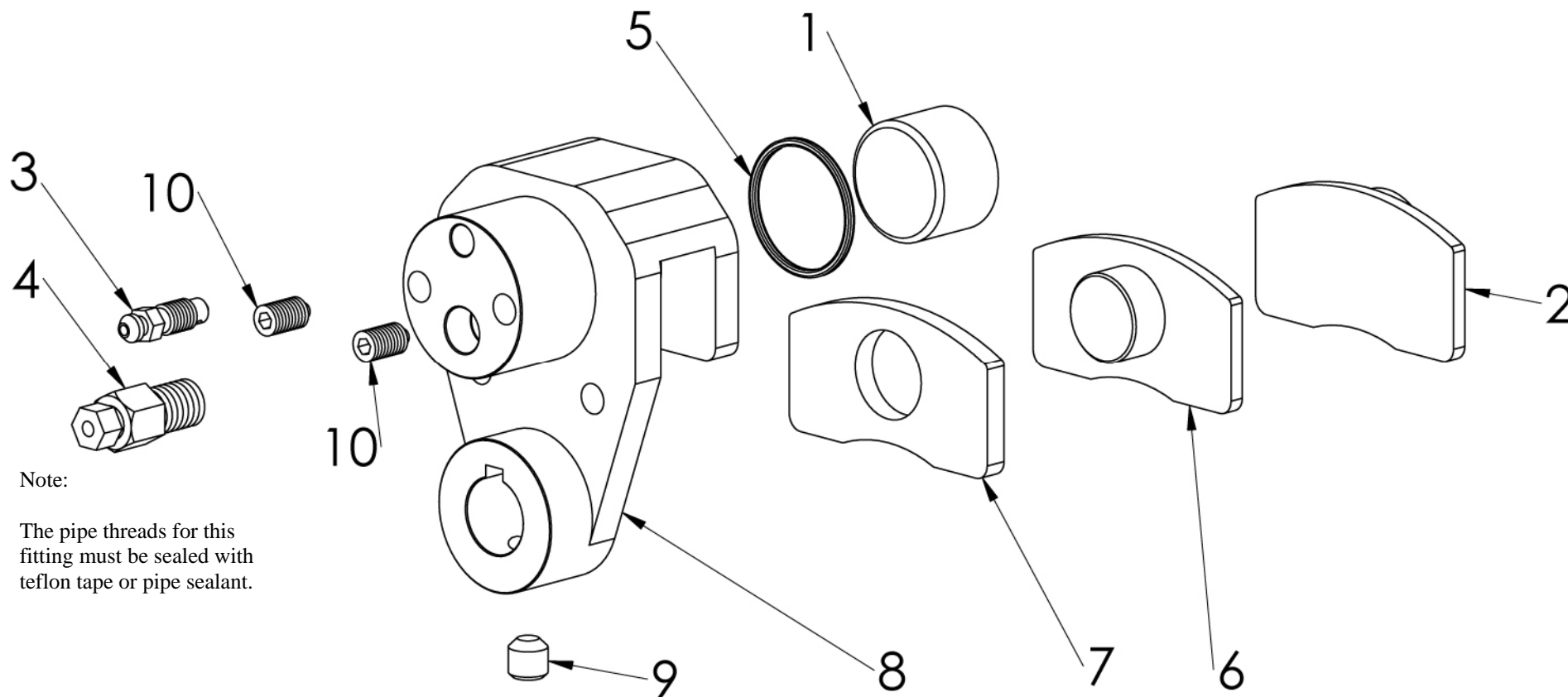

**Note:**

The pipe threads for this fitting must be sealed with teflon tape or pipe sealant.

ITEM NO.	PART NUMBER	DESCRIPTION	QTY.
1	44740	Caliper piston	1
2	44753	Outer brake pad	1
3	44767	Bleeder screw	1
4	44756	1/8" NPT to 1/8" tube compression fitting	1
5	44765	Quad ring seal	1
6	44751-1	inner brake pad	1
7	44752-1	Inner brake pad backer	1
8	44741	caliper housing	1
9	44757	5/16-18 set screw	1
10	44827	Bleeder screw hole plug	2

Notice: Item 3 (bleeder screw) must be located in the top position to assure all air is bled from the system. Use item 10 (Bleed screw hole plug) to plug of the other two bleeder screw locations. These locations are used in cases where the caliper needs to be mounted 90 degrees left or right.

**Notes:**

**UNLESS OTHERWISE SPECIFIED:**  
 DIMENSIONS ARE IN INCHES  
 TOLERANCES:  
 FRACTIONAL  $\pm 1/8"$   
 ANGULAR: MACH  $\pm .5^\circ$  BEND  $\pm 1^\circ$   
 TWO PLACE DECIMAL  $\pm .030$   
 THREE PLACE DECIMAL  $\pm .005$

MATERIAL

FINISH

DO NOT SCALE DRAWING



TITLE:

**BX-1000 caliper assembly**

Part #

**44766**

Qty Req'd

SCALE: 1:8

WEIGHT:

REV:



## 1. Mount Tire *(See Split Rim Section for Mounting Split Rims)*

Apply soapy water to edge of tire bead and wheel rim. Push one side of tire on to rim at a time with a twisting motion at a slight angle. Place a wood block under rim and with firm pressure seat the bottom tire bead to the bottom rim. (Make sure valve stem is facing up) Flip the tire and rim and set the tire between two wood blocks or a 5 gallon bucket. Connect air chuck and with the air flowing into rim press down on the rim to seat the top edge of tire bead. Inflate to desired pressure.



## 2. Mount Hub To Wheel

Attach the hub to the wheel on the opposite side of valve stem with supplied hex headed bolts. Apply the flange nuts to the back side of hex headed bolts to secure hub to wheel.

*Note: Make sure to insert lock washers under the bolt head*



## 3. Mount Axle to Frame

Tap woodruff key into the axle and attach the supplied 5/8" axle to your frame. *(Note the caliper can be mounted vertical or horizontal by locating the bleeder screw at the highest location (plugging the other two with the supplied plugs)* Locate the desired position of the axle before drilling the axle.

*(Note: You may need to fabricate your own mounting system or contact FBI for custom made mounting hardware.)*

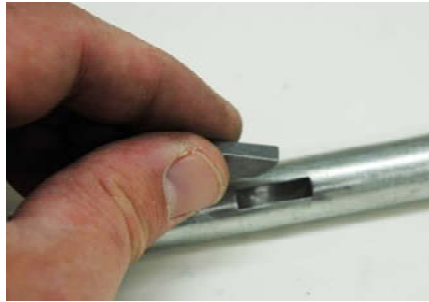

## 4. Apply Sealant To Fitting

Apply either loctite sealant or teflon tape to the straight thread of the compression fitting. Rap the tape in the direction shown in the picture or use loctite 592 thread sealant instead of the tape.

*Note: sealant is not used on the plugs or the bleeder screw*

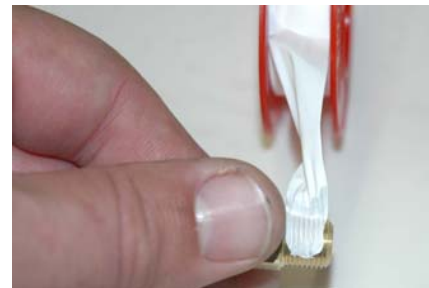

## 5. Install Caliper Hardware

Tighten down the bleeder screw plugs into the opposite holes of where you are going to locate your bleeder screw at the highest position of the piston. When the plugs are inserted the nylon tip will form to the shape of the seat. *(Do not over tighten)*



## 6. Install Caliper to Axle

Tighten up the compression fitting and insert the caliper on to the axle and slide it over the woodruff key. *Make sure you use sealant on the pipe thread side of the fitting. Teflon tape or loctite thread sealant.*

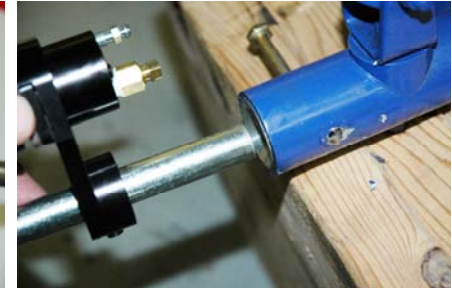

## 7. Install Brake Line and Compression Fittings

Secure the caliper to the axle by tightening the set screw located at the bottom of the caliper. Connect the straight compression fittings to the calipers and master cylinder making sure to use either teflon tape or loctite thread sealant on the pipe threads only. You do not need to seal the threads on the bleeder screw, bleeder screw plugs, or the compression fitting threads, just the pipe threads going into the caliper and the master cylinder. Using the "T" connector, route the brake line and connect both calipers to the master cylinder by inserting the brake line about 1/2" through the male compression fitting into the female fitting keeping the line inside fitting as far as it will go and then tighten the male fitting.

Note: On the straight compression fitting the ferrule will break free from the male compression fitting once it has been tightened and crimp on to the brake line. The TEE compression fitting will also crimp on to the brake line after the nut has been tightened.

Route the line between the calipers and the TEE keeping the distance as short as possible.

*Make sure to use Teflon tape or pipe sealant on pipe threads going into the caliper*

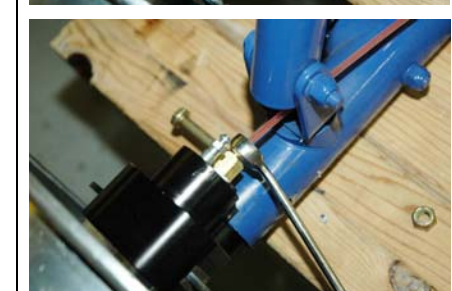

## 8. Insert The Rotor

Slide the rotor over the axle and between the pads in the caliper. Hold it there while sliding the wheel hub assembly on to the axle.



## 9. Mount the Wheel

Slide the wheel on to the axle and locate the pins (Socket Head Cap Screws) on the Azusa adaptor to the holes on the rotor. Slide the wheel up tight and make sure the pins are still located in the holes of the rotor.



## 10. Secure the Locknut

Tighten main axle nut up slightly snug and back it up 1/4 turn or until wheel spins freely.

*Note: This rotor is a full floating rotor and does not have any other mounting hardware to fasten to the wheel hub.*



## 11. Mount Master Cylinder

Slide Master cylinder over 1" control stick locating the brake handle forward and secure by tightening the clamp screw. Remove reservoir plug and fill the chamber with Hydraulic Fluid or ATF fluid. Crack the bleeder screw and bleed the air from the lines and caliper. Note you will need to add more oil after every 2 pumps. Continue until all the air is gone and hold pressure on the handle and retighten the bleeder screw. Repeat this for the other caliper. Once you have bled the system leave the oil level below the depth of the plug to prevent seepage when reinserting the cap.

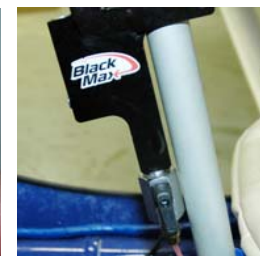
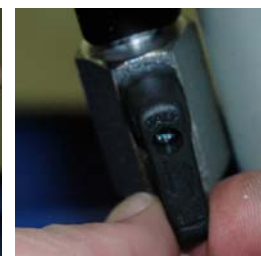
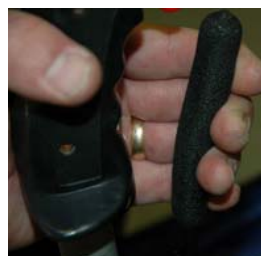

# Black Max Split Rim

## Assembly Instructions

Apply a thin layer of grease to the both halves of the split rim.



Grease to the O-Ring and align the spacer plate with the holes in the rim



Insert hub bolt and lock washer through the front side of the rim half (The half with the valve stem) and O-Ring spacer plate



Apply soapy water to both sides of the tire bead and insert front half and back half of the rim together using the 3 hub bolts. Insert hub bolts from the valve stem side.



Tighten the bolts to the hub attach the flange nuts to the excess thread protruding from the back of the hub to secure the hub bolts for safety.



Use a ratchet strap to help seal the bead. Apply air pressure and release the strap as the bead begins to seal before there is too much pressure on the strap



# WARRANTY

**1 YEAR LIMITED WARRANTY ON ALL PARTS ONLY  
UNDER CONDITIONS OF NORMAL AND INTENDED USE.  
MISUSE, DAMAGE OR ALTERATION OF ANY  
COMPONENT VOIDS THE WARRANTY.**

**BRAKE PADS AND ROTORS ARE EXCLUDED FROM  
WARRANTY**

**USE OF ANY OTHER FLUID OTHER THAN ATF FLUID  
VOIDS THIS WARRANTY.**

**NO OTHER WARRANTIES WRITTEN, VERBAL, IMPLIED  
OR OTHER THAN LISTED HERE WILL BE HONORED.**



**1380 LEGION ROAD  
DETROIT LAKES, MN 56501  
PHONE: (218) 847-2862 (800) 850-3708  
Website: [www.flyfbi.com](http://www.flyfbi.com)  
Email: [salesdept@flyfbi.com](mailto:salesdept@flyfbi.com)**