

Air Wave **VORTEX GENERATORS**

Rev 1 July 2010

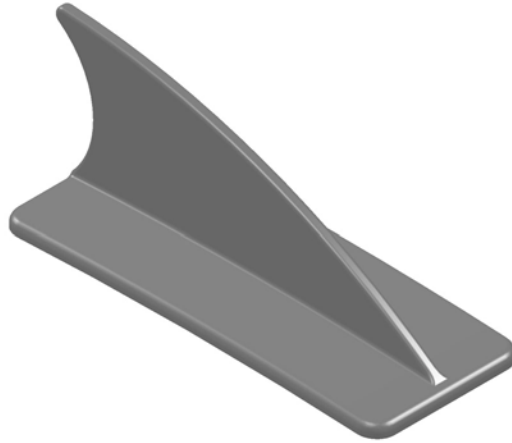

It has been known for some time now that vortex generators reduce stall speeds and improve the aircraft's handling performance. Vortex generators allow the wing to develop more lift and lower airspeeds. This reduces takeoff speed and improves the rate of climb. Vortex Generators also retain positive aileron control and enhance your rudder authority in higher angles of attack. You will immediately notice an improvement in your aircraft.

HOW TO THEY WORK?

As air normally flows over the wing of an aircraft in flight, the air "sticks" to the surface of the wing. This adherence to the wing's surface produces lift. If the airflow loses its adherence and separates from the wing, aircraft performance can suffer in the form of increased drag, loss of lift and higher fuel consumption.

Researchers at NASA Langley Research Center developed Micro VGs to control this flow detachment by producing miniature, controlled tornadoes, called "vortices". The Micro VGs sweep away uncontrolled airflow separation over the airplane's wings and flaps with the benefit of reduced drag and increased lift (i.e., less engine power needed to produce the same lift).

Micro VG technology contributed to performance and safety improvements as well as cost and noise reduction for the aerospace industry. Its relatively simple design and ease of installation make Micro-Vortex Generators one of the most cost-effective means of aircraft safety and performance enhancement.

Placement for Wing Installations

When placed on a wing, the center of the VG should be 8% - 12% aft of the leading edge. For most installations a placement of 10% is ideal. The length is measured along the "chord" and should not be measured along the curved portion.

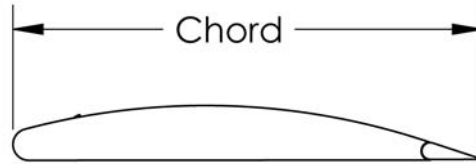

The chord position should be measured from the front edge of the wing to the aft side of the ailerons or flaps.

As an example the Freebird wing chord is 68" so you would want to put the middle of the Air Wave VG about 6.8" back from the leading edge of the wing.

The spacing of each VG should be about 1% of the wing span apart.

For Example the wing span is 26'4" long which is 316". (316 x .01 = 3.16) If you place them about 3" apart would be just about right.

Align the VG's at 15 degree angles to the air stream **NOT** to the leading edge of your wing.

Each VG should be staggered or go in the opposite direction from the next VG in line. Don't group the VG's in pairs, evenly space them.

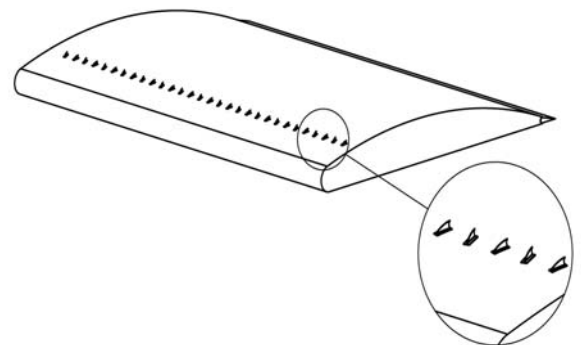
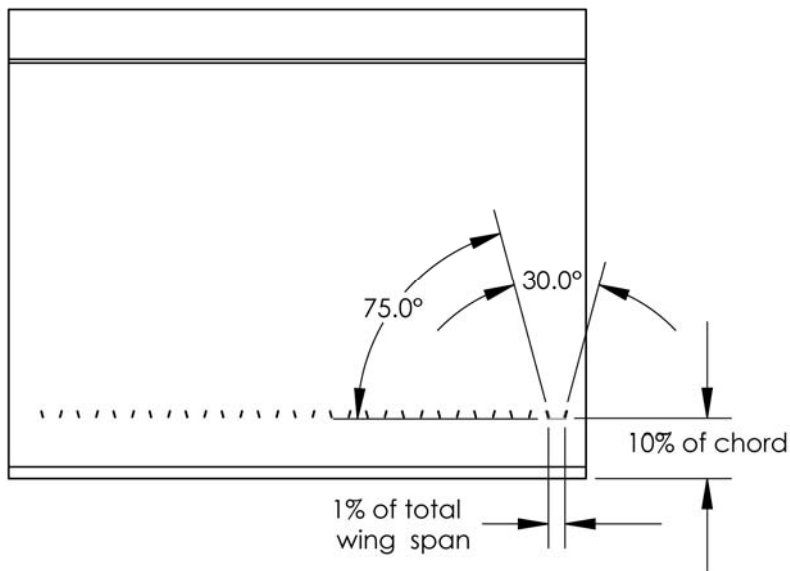

Placement for Control Surface Installations

Vertical Stabilizer

When installing the AirWave Vortex Generators on the vertical stabilizer, align to the airflow when flying slow (high angle of attack), since stalls on most wings generally take place at around a 17 degree angle of attack then placing the VG's at a 15 degree angle to the airflow when the aircraft is flying straight level will not put the VG's at 15 degrees when flared. Place the VG's on both sides of the vertical stabilizer at approximately 3" apart just in front of the hinge line or at the back of the vertical stabilizer. Place the VG's at an angle between zero and five degrees in a level flight attitude.

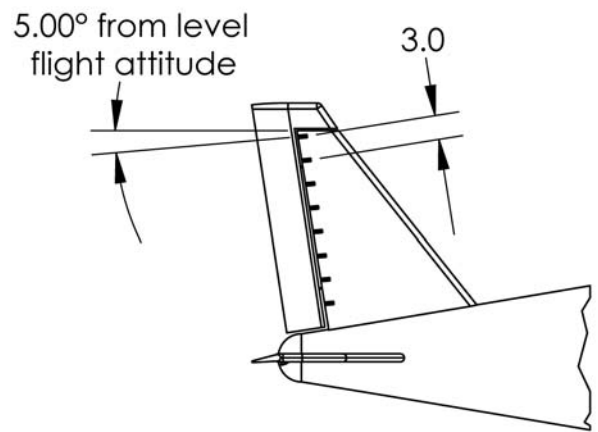

Horizontal Stabilizer

Place the Airwave Generators at 15 degree angles to the airflow just like on the wings but put them just slightly in front of your elevator hinge line on the **BOTTOM** of your horizontal stabilizer spaced 1.5" apart.

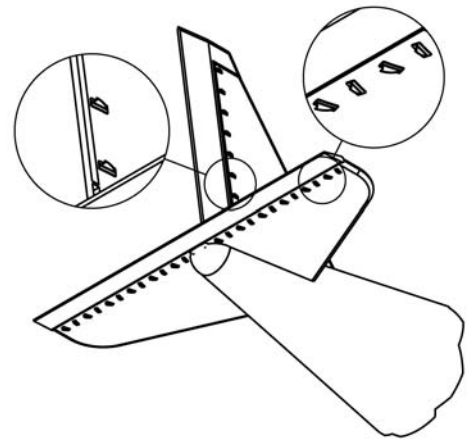

Warning – Caution

Most people will attach their VG's in a temporary manor to test and assure that they are located in the optimum position.

- Use tape that will not come off. Unequal placement of VG's can cause instability and control issues
- Do not apply VG's to just one wing. This could cause negative flight characteristics.
- Use thin double sided tape like the 3M brand which can be found at most hardware stores
- Do not use the thick kind of tape with the filament reinforcements
- Clean the wing area with rubbing alcohol to eliminate any dust, oil, etc before applying the tape.
- Do not apply the tape in temperatures below 60 degrees Fahrenheit
- This product does not hold an STC rating for any aircraft. This product is intended for use with experimental or ultralight aircraft.

Permanent Installation

Once the temporary location of the VG's has been confirmed you will need to bond the VG with a permanent adhesive.

1. Mark a straight line along the leading edge of your wing at the desired Chord location explained earlier in this manual.
2. Remove the VG and clean both the surface of the VG and the area that it will be bonded too with a non-solvent based cleaner to remove all traces of dust, oils, or other contaminants
3. We highly recommend using a primer/activator along with adhesive as it preps the surface for a better bond.

Adhesive recommendations:

- A. Loctite® "Prism" 401 cyanoacrylate adhesive
- B. Pacer® Technologies (Super Glue) "Plasti-Fuse" #15104 (with primer/activator included)
- C. Permatex® "Auto Trim Adhesive" #80885 (with primer/activator included)

100% Money Back Guarantee

If for any reason you are not satisfied with this product simply return it for a refund.



Free Bird Innovations, Inc.
1380 LEGION ROAD ▪ PO Box 904 ▪ DETROIT LAKES, MN 56501
PHONE: (218) 847-2862 (800) 850-3708 ▪ Website: www.freebirdinnovations.com
email: salesdept@freebirdinnovations.com

